

Load Rating Chart

Model 35124C & 35124T



© Manitex

NOTE: Additional copies of this Load Rating Chart can be purchased from your Manitex Distributor. When ordering, use the part number shown in the bottom left corner of this page.

RANGE DIAGRAM - FULL SPREAD CONFIGURATION -

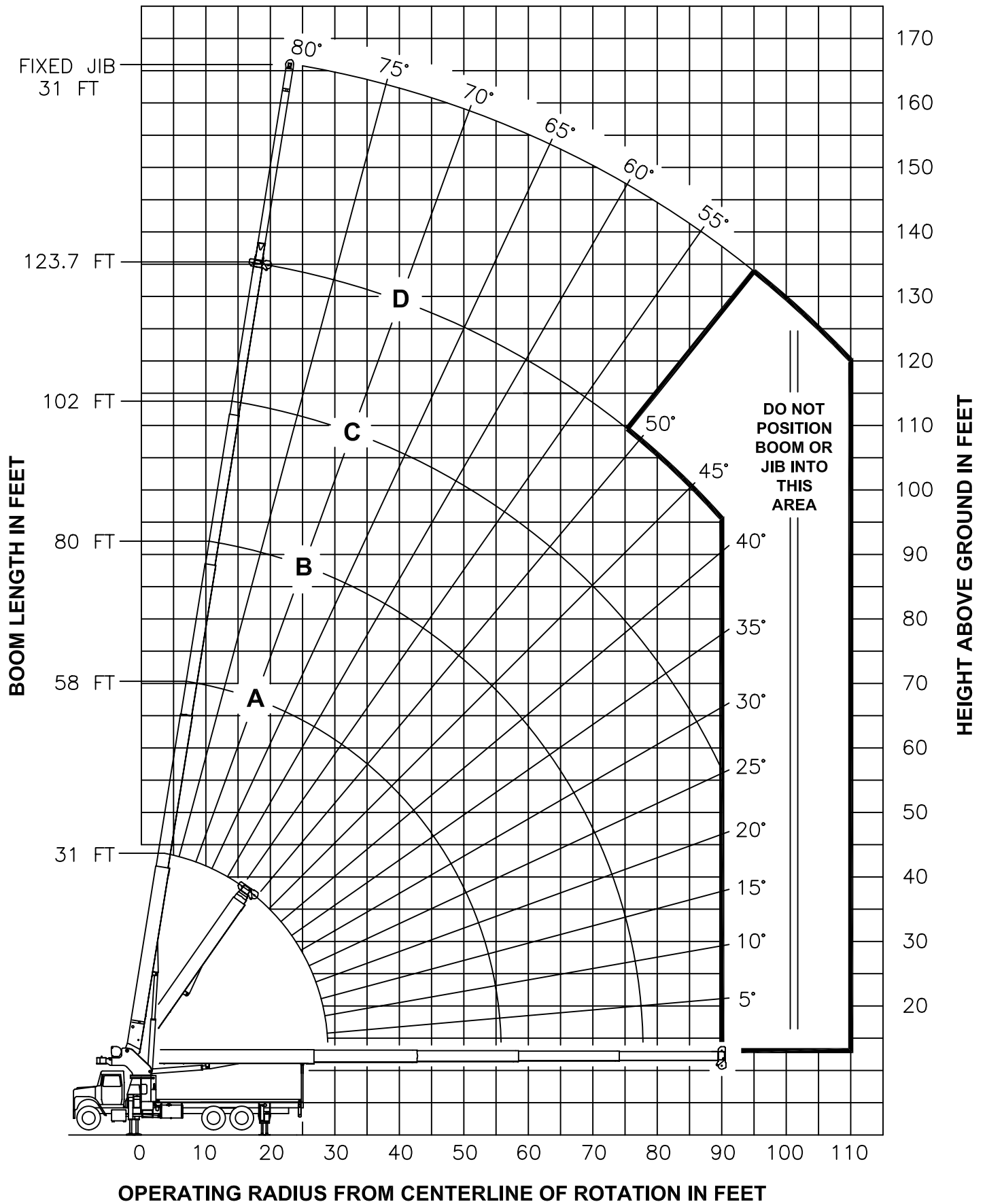

**USE THIS CHART ONLY
WHEN OUTRIGGERS
AND STABILIZERS ARE
FULLY EXTENDED**

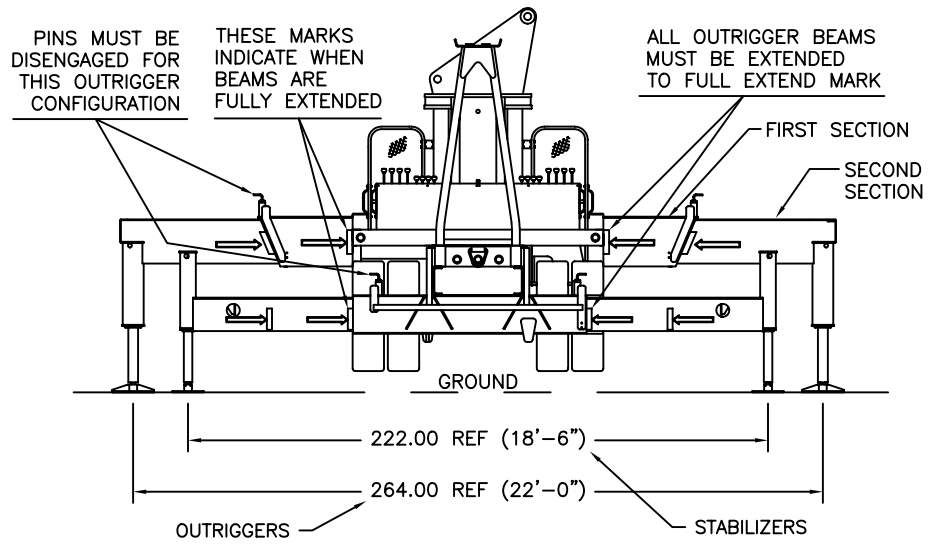

- FULLY EXTENDED OUTRIGGER CONFIGURATION -

		MAIN BOOM LOAD RATINGS IN LBS								JIB LOAD RATINGS IN LBS			
		LMI CODE #1								LMI CODE #2			
OPERATING RADIUS FT	LOADED BOOM ANGLE BOOM LENGTH AND MARKER	A		B		C		D		OPERATING RADIUS FT	BOOM ANGLE	31 FT JIB FOR ALL BOOM LENGTHS SEE WARNING NOTE 4	
		31 FT	58 FT	80 FT	102 FT	123.7 FT	31 FT JIB FOR ALL BOOM LENGTHS SEE WARNING NOTE 4						
6	81	70000											
8	76	53390											
10	72	45380								10			
12	68	39420	79	25000						12			
15	61	33110	76	25000	81	21500				15			
20	49	23710	71	22870	78	19700	81	14500		20			
25	34	17680	65	18280	74	17420	79	13500	81	8450	25		
30			60	14150	70	14320	76	12820	79	8150	30	81	4000
35			53	11080	66	11270	73	11370	76	7800	35	79	3850
40			47	8590	62	8770	69	8870	74	7280	40	77	3700
45			39	6780	57	6960	66	7050	72	6780	45	75	3550
50			29	5400	52	5580	63	5660	69	5710	50	73	3400
55			13	4320	47	4490	59	4570	66	4620	55	71	3250
60					42	3620	56	3700	64	3740	60	69	3080
65					36	2890	52	2970	61	3020	65	67	2910
70					28	2290	48	2370	58	2410	70	66	2740
75					18	1770	44	1850	55	1900	75	64	2220
80							39	1410	52	1450	80	62	1770
85							34	1030	49	1070	85	60	1390
90							28	690	45	730	90	57	1050
95											95	55	750
		450 LBS	240 LBS	180 LBS	140 LBS	120 LBS	DEDUCTIONS FOR STOWED JIB						

RANGE DIAGRAM - INTERMEDIATE SPREAD CONFIGURATION - (MID EXTEND)

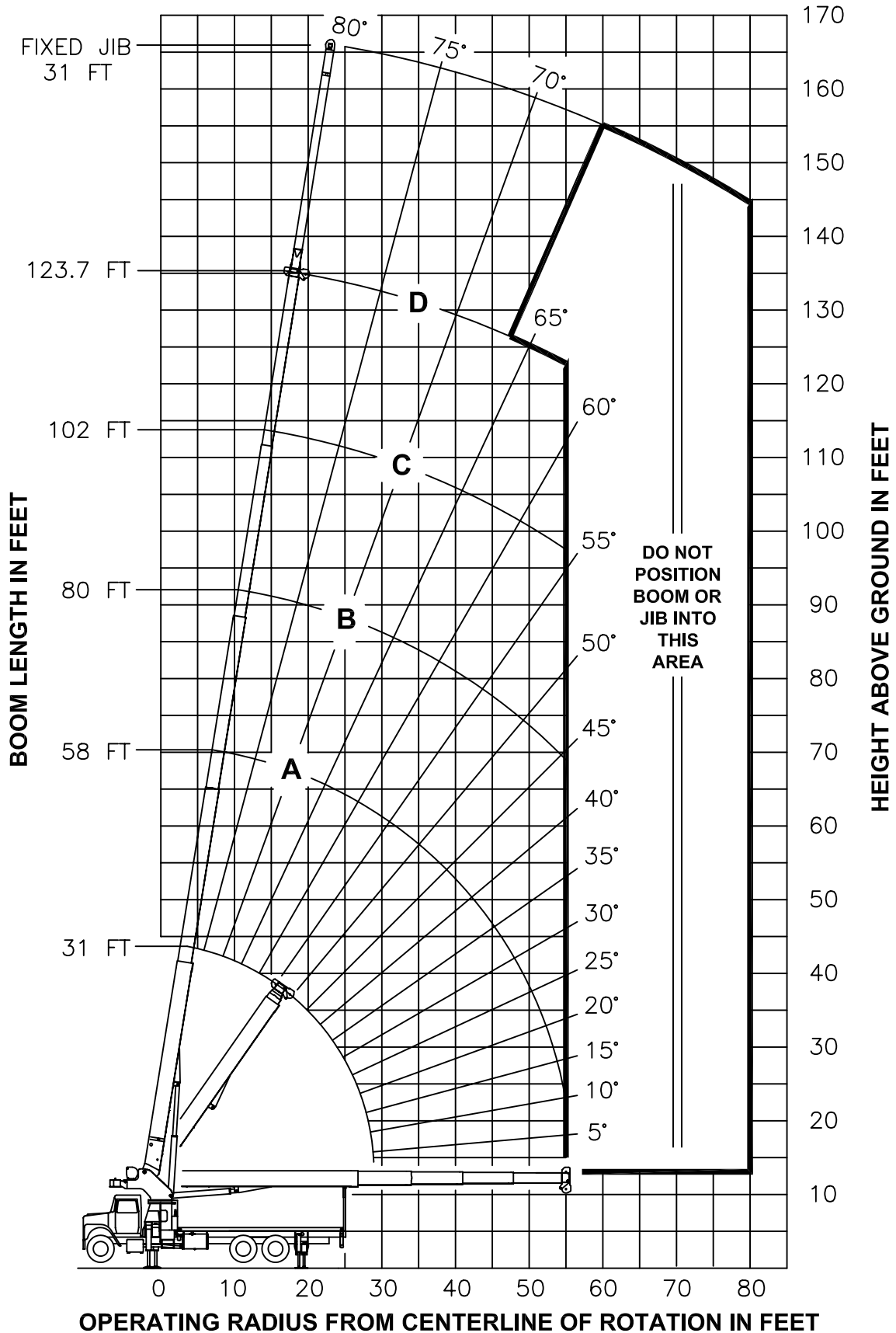

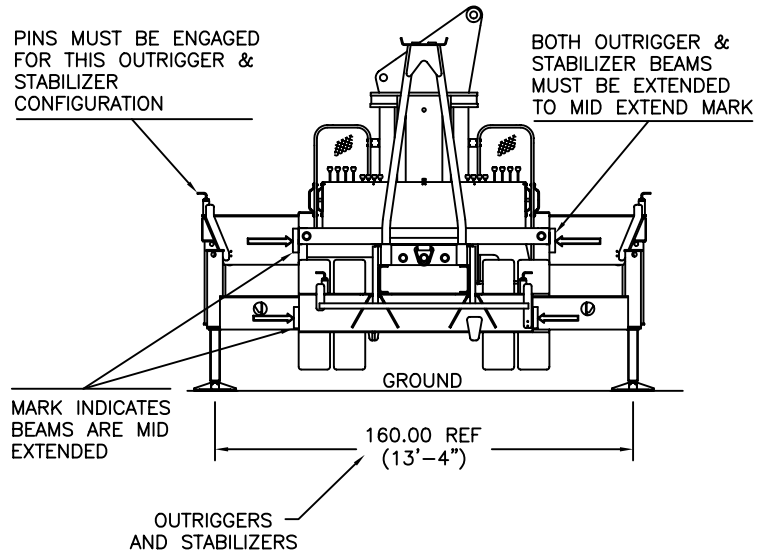

**USE THIS CHART ONLY
WHEN FRONT
OUTRIGGERS AND REAR
STABILIZERS ARE IN THE
INTERMEDIATE POSITION**

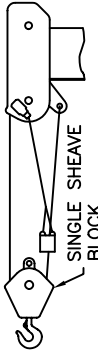

**- INTERMEDIATE SPREAD CONFIGURATION -
(MID EXTEND)**

		MAIN BOOM LOAD RATINGS IN LBS						JIB LOAD RATINGS IN LBS					
		LMI CODE #9						LMI CODE #10					
OPERATING RADIUS FT	LOADED BOOM ANGLE BOOM LENGTH AND MARKER												
			A		B		C		D		OPERATING RADIUS FT	BOOM LOAD ANG	31 FT JIB FOR ALL BOOM LENGTHS SEE WARNING NOTE 4
			31 FT	58 FT	80 FT	102 FT	123.7 FT						
6	81	70000											
8	76	53390											
10	72	45380								10			RATED LOAD IN POUNDS
12	68	39420	79	25000						12			
15	61	24930	76	25000	81	21500				15			
20	49	13570	71	14300	78	14520	81	14500		20			
25	34	8400	65	9080	74	9280	79	9380	81	8450	25		
30			60	6090	70	6280	76	6370	79	6430	30	81	4000
35			53	4160	66	4340	73	4430	76	4480	35	79	3850
40			47	2810	62	2980	69	3060	74	3110	40	77	3430
45			39	1810	57	1970	66	2060	72	2100	45	75	2410
50			29	1030	52	1200	63	1280	69	1330	50	73	1640
55					47	590	59	670	66	710	55	71	1020
60											60	69	520
		450 LBS	240 LBS	180 LBS	140 LBS	120 LBS	DEDUCTIONS FOR STOWED JIB						

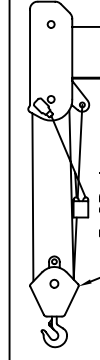
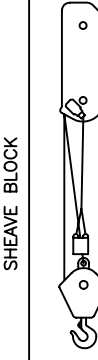
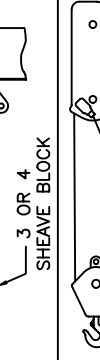
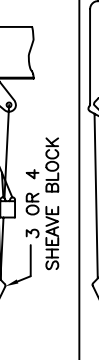
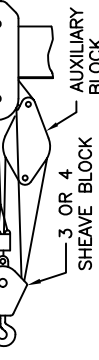
ALLOWABLE LINE PULL								WARNING
1 PART LINE	2 PART LINE	3 PART LINE	4 PART LINE	5 PART LINE	6 PART LINE	7 PART LINE	8 PART LINE	
								<p>ANTI-TWO-BLOCK SYSTEM MUST BE IN GOOD OPERATING CONDITION BEFORE OPERATING CRANE.</p> <p>REFER TO THE OWNER'S MANUAL.</p> <p>KEEP AT LEAST 3 WRAPS OF LOAD LINE ON THE DRUM AT ALL TIMES.</p>
9080 LBS	18160 LBS	27240 LBS	36320 LBS	45400 LBS	54480 LBS	63560 LBS	70000 LBS	5/8" ROT RESISTANT (5.0:1 SF) - 45400 LBS MIN BREAKING STRENGTH
9500 LBS	19000 LBS	28500 LBS	38000 LBS	47500 LBS	57000 LBS	66500 LBS	70000 LBS	5/8" 6 X 25 IWRC (3.5:1 SF) - 33250 LBS MIN BREAKING STRENGTH

AREA OF OPERATION

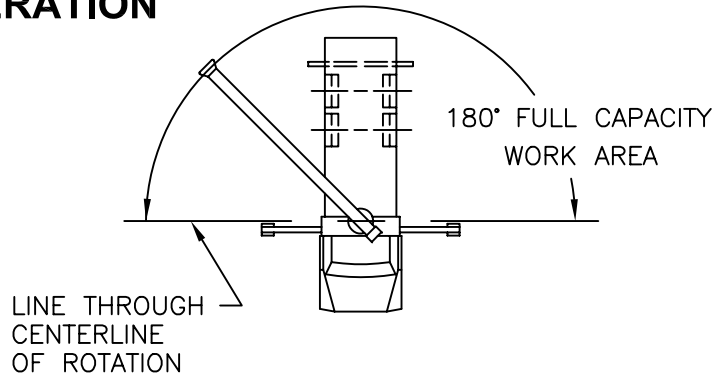

DEDUCTIONS FROM RATED LOADS FOR LOAD HANDLING DEVICES SUPPLIED BY MANITEX.

AUXILIARY BLOCK	—	—	—	—	—	—	—	—	50 LBS
OVERHAUL BALL	—	—	—	—	—	—	—	—	SEE OVERHAUL BALL MANUFACTURER NAMEPLATE
LOAD BLOCK	—	—	—	—	—	—	—	—	SEE BLOCK MANUFACTURER NAMEPLATE
HOSE REEL	—	—	—	—	—	—	—	—	260 LBS
SWING AROUND JIB	—	—	—	—	—	—	—	—	SEE LOAD CHART

LMI OPERATING CODES

SETTING	CRANE CONFIGURATION	OUTRIGGER CONFIGURATION
#1	— MAIN BOOM	FULLY EXTENDED
#2	— FIXED JIB	FULLY EXTENDED
#5	— PERSONNEL LIFTING PLATFORM ON MAIN BOOM	FULLY EXTENDED
#6	— PERSONNEL LIFTING PLATFORM ON FIXED JIB	FULLY EXTENDED
#9	— MAIN BOOM	INTERMEDIATE
#10	— FIXED JIB	INTERMEDIATE

WARNING

1. THE OPERATOR MUST READ AND UNDERSTAND THE OWNER'S MANUAL BEFORE OPERATING THIS CRANE.
2. POSITIONING OR OPERATION OF CRANE BEYOND AREAS SHOWN ON THIS CHART IS NOT INTENDED OR APPROVED EXCEPT WHERE SPECIFIED IN OWNER'S MANUAL.
3. LOADED BOOM ANGLES AT SPECIFIED BOOM LENGTHS GIVE ONLY AN APPROXIMATION OF THE OPERATING RADIUS. THE BOOM ANGLE BEFORE LOADING SHOULD BE GREATER TO ACCOUNT FOR DEFLECTIONS. DO NOT EXCEED THE OPERATING RADIUS FOR RATED LOADS.
4. THE OPERATING RADIUS SHOWN IN THE JIB RATING CHART IS FOR FULLY EXTENDED BOOM ONLY. WHEN BOOM IS NOT FULLY EXTENDED, USE ONLY LOADED BOOM ANGLE TO DETERMINE LOAD RATING OF JIB.
5. FOR BOOM ANGLES NOT SHOWN ON JIB LOAD RATING CHART, USE RATING OF NEXT LOWER BOOM ANGLE.
6. FOR BOOM LENGTHS NOT SHOWN, USE RATING OF NEXT SHORTER OR LONGER BOOM LENGTH, WHICHEVER IS LESS. FOR RADII NOT SHOWN, USE RATING OF NEXT LONGER RADIUS.
7. CRANE LOAD RATINGS ON OUTRIGGERS ARE BASED ON FREELY SUSPENDED LOADS WITH THE MACHINE LEVELED AND STANDING ON A FIRM UNIFORM SUPPORTING SURFACE. NO ATTEMPT SHALL BE MADE TO MOVE A LOAD HORIZONTALLY ON THE GROUND IN ANY DIRECTION.

WARNING (CONTINUED)

8. PRACTICAL WORKING LOADS DEPEND ON SUPPORTING SURFACE, WIND, AND OTHER FACTORS AFFECTING STABILITY SUCH AS HAZARDOUS SURROUNDINGS, EXPERIENCE OF PERSONNEL, AND PROPER HANDLING, ALL OF WHICH MUST BE TAKEN INTO ACCOUNT BY THE OPERATOR.
9. THE MAXIMUM LOAD WHICH MAY BE TELESCOPED IS LIMITED BY HYDRAULIC PRESSURE, BOOM ANGLE, AND BOOM LUBRICATION. IT IS SAFE TO ATTEMPT TO TELESCOPE ANY LOAD WITHIN THE LIMITS OF THE LOAD RATING CHART.
10. LIFTING OFF THE MAIN BOOM POINT WHILE THE SWING AROUND JIB IS ERECTED IS NOT INTENDED OR APPROVED.

INFORMATION

1. DEDUCTIONS MUST BE MADE FROM RATED LOADS FOR STOWED JIB, OPTIONAL ATTACHMENTS, HOOKS, AND LOADBLOCKS (SEE DEDUCTION CHART). WEIGHTS OF SLINGS AND ALL OTHER LOAD HANDLING DEVICES SHALL BE CONSIDERED A PART OF THE LOAD.
2. LOAD RATINGS ABOVE THE HEAVY LINE ARE STRUCTURALLY LIMITED CAPACITIES. LOAD RATINGS BELOW THE HEAVY LINE ARE STABILITY LIMITED CAPACITIES AND DO NOT EXCEED 85% OF TIPPING.

DEFINITIONS

1. OPERATING RADIUS IS THE HORIZONTAL DISTANCE FROM THE AXIS OF ROTATION TO THE CENTER OF THE VERTICAL HOIST LINE OR TACKLE WITH LOAD APPLIED.
2. LOADED BOOM ANGLE AS SHOWN IN THE COLUMN HEADED BY \angle , IS THE INCLUDED ANGLE BETWEEN THE HORIZONTAL AND LONGITUDINAL AXES OF THE BOOM BASE AFTER LIFTING RATED LOAD AT RATED RADIUS.



Las Vegas • San Bernardino

RENTALS / SALES / PARTS / SERVICE

LAS VEGAS **1-800-598-3465** **SAN BERNARDINO**
2730 N. HELLIS BLVD. **1185 E. COOLEY AVENUE**
LAS VEGAS, NV 89115 **SAN BERNARDINO, CA 92408**

WWW.INQUIPCO.COM