



# TEREX STINGER™ 3470 Boom Truck Crane



## FEATURES

- **34,000 lbs. (15 422 kg) maximum lifting capacity**
- **80 ft. (24.4 m) maximum sheave height**
- **120 ft. (36.6 m) maximum sheave height with 40 ft. (12.2 m) jib**
- 70 ft. (21.3 m) fully proportional three-section telescopic “keel” boom
- Exclusive color coded boom and load charts
- Easy-to-install optional 24-40 ft. (7.3-12.2 m) jib, man baskets or work platform increase job capabilities
- Choice of two configurations – behind cab with either 180° or 360° work area and rear mount
- Electronic Load Moment Indicator and anti-two-block device standard
- 2-speed planetary winch has 11,400 lb. (5171 kg) maximum line pull, 150/220 fpm (46/67 mpm) line speed
- Externally located planetary rotation drive for easy accessibility for maintenance
- Dual control stations with direct mechanically controlled hydraulic system
- 67 gal. (340 l) capacity hydraulic tank
- Terex Support Plus product service

simple, available and  
cost effective™

Machines shown may have optional equipment.

# STINGER 3470 LOAD RATINGS



**CAUTION:** Do not use this specification sheet as a load rating chart. The format of data is not consistent with the machine chart and may be subject to change.

## Load Ratings (Pounds) for 360° Full Capacity Work Area with Outriggers Extended and Optional Front Stabilizer

OPERATING RADIUS (FT)	BOOM LENGTH											
	27 FT		34 FT		43 FT		52 FT		61 FT		70 FT	
	LOADED BOOM ANGLE (DEG)	LOAD RATING (LB)	LOADED BOOM ANGLE (DEG)	LOAD RATING (LB)	LOADED BOOM ANGLE (DEG)	LOAD RATING (LB)	LOADED BOOM ANGLE (DEG)	LOAD RATING (LB)	LOADED BOOM ANGLE (DEG)	LOAD RATING (LB)	LOADED BOOM ANGLE (DEG)	LOAD RATING (LB)
5	77	34,000										
10	66	21,100	71	17,100	75	16,000	78	15,700				
15	54	15,100	62	14,000	68	12,100	72	11,100	75	10,800	77	9,600
20	39	11,100	51	10,100	61	9,100	66	8,600	71	8,200	73	7,300
25	17	7,900	40	7,700	53	7,100	61	6,900	66	6,600	69	5,900
30			23	6,500	44	6,100	54	5,600	60	5,300	64	4,900
35					33	4,800	47	4,700	54	4,600	60	4,150
40					16	3,500	38	4,100	48	3,900	55	3,550
45							27	3,250	41	3,200	49	3,050
50							9	2,950	33	2,800	44	2,650
55									23	2,500	37	2,350
60											29	1,900
65											19	1,700

NOTE: RATINGS ABOVE THE HEAVY LINE ARE BASED ON STRUCTURAL COMPETENCE AND NOT ON MACHINE STABILITY.

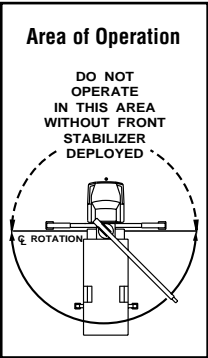

**Deductions from Rated Loads for Handling Devices**

OVERHAUL BALL:	125 lbs.
1 SHEAVE LOAD BLOCK:	200 lbs.
2 SHEAVE LOAD BLOCK:	230 lbs.
AUXILIARY SHEAVE:	50 lbs.

### Stowed Jib Deductions (Pounds)

450	360	260	230	200	175
-----	-----	-----	-----	-----	-----

### JIB CAPACITIES FOR ALL BOOM LENGTHS

VERIFY OPERATIONAL MODE SETTING ON MG585 DISPLAY BEFORE LIFTING WITH JIB

Loaded Boom Angle	35°	40°	45°	50°	55°	60°	65°	70°	75°	80°
Retracted 24 ft. Jib	700	825	1000	1150	1340	1600	1900	2300	3100	4160
Extended 40 ft. Jib	520	580	650	730	810	930	1080	1400	1810	2260

### General Notes

- The operator must read and understand the Owner's Manual before operating this crane.
- Positioning or operation of crane beyond areas shown on this chart is not intended or approved except where specified in Owner's Manual.
- Loaded boom angles at specified boom lengths give only an approximation of the operating radius. The boom angle before loading should be greater to account for deflections. Do not exceed the operating radius for rated loads.
- Use rating of next longer boom for boom lengths not shown. Use rating of next greater radius for load radii not shown.
- Boom must be fully retracted when jib is erected before lowering below minimum angle. Retracted jib has no lifting capacity below a 50° boom angle.
- Use rating of next lower boom angle for boom angles not shown on jib load rating chart.
- Lifting off the main boom point while the swing around jib is erected is not intended or approved.
- Do not lower boom into this area, as hydraulic pressure will not allow raising the boom without retracting boom first.
- Crane load ratings on outriggers are based on freely suspended loads with the machine leveled and standing on a firm uniform supporting surface. No attempt shall be made to move a load horizontally on the ground in any direction.

- Practical working loads depend on supporting surface, wind and other factors affecting stability such as hazardous surroundings, experience of personnel, and proper handling, must all be taken into account by the operator.
- The maximum load which may be telescoped is limited by hydraulic pressure, boom angle, and boom lubrication. It is safe to attempt to telescope any load within the limits of the load rating chart.

#### INFORMATION

- Deductions must be made from rated loads for stowed jib, optional attachments, hooks and loadblocks (see deduction chart). Weights of slings and other load handling devices shall be considered a part of the load.
- Crane load ratings with outriggers are based on outriggers and stabilizers extended and set with all load removed from the carrier wheels.
- Load ratings do not exceed 85% of tipping load.



#### DEFINITIONS

- Operating radius is the horizontal distance from the axis of rotation to the center of the vertical hoist line or load hook with load suspended.
- Loaded boom angle as shown in the Load Ratings Chart is the included angle between the horizontal and longitudinal axes of the boom base after lifting rated load at rated radius.

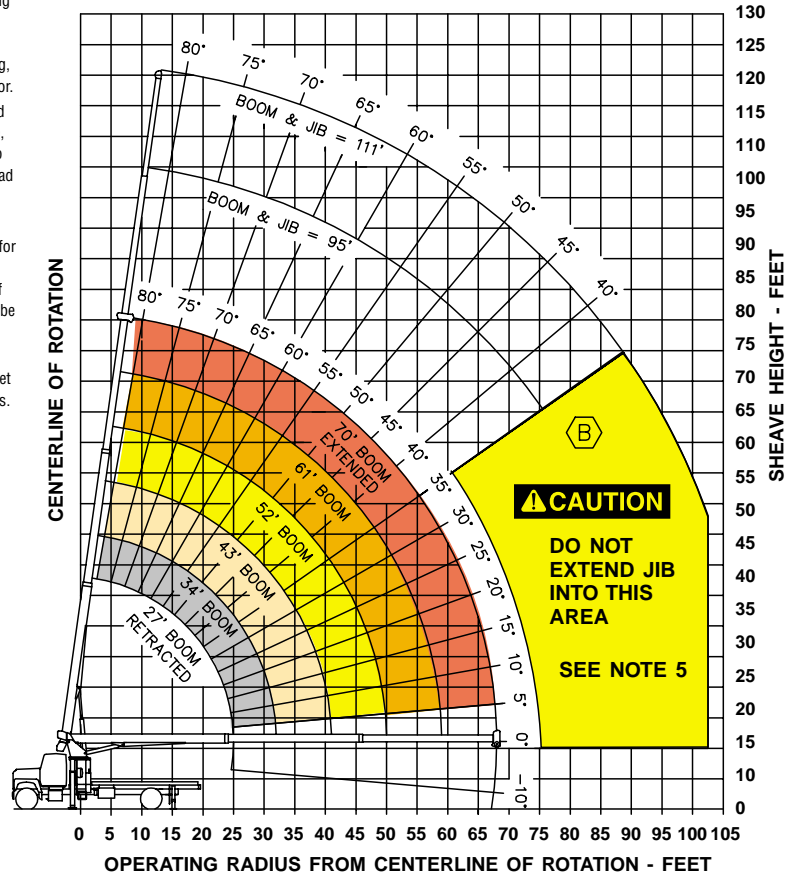
### Range Diagram (27' - 70' boom)

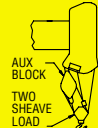

# WINCH DATA

		1 Part Line	2 Part Line	3 Part Line	4 Part Line
					
Winch	Cable Supplied	Lift and Speed	Lift and Speed	Lift and Speed	Lift and Speed
Standard Stationary Winch	9/16" Diam. IWRC XXIP	9,600 lb. 94 fpm*	19,200 lb. 47 fpm*	28,800 lb. 32 fpm*	34,000 lb. 24 fpm*
	9/16" Diam. Rotation Resistant	6,720 lb. 94 fpm*	13,440 lb. 47 fpm*	20,160 lb. 32 fpm*	26,880 lb. 24 fpm*

Block Type	Rating
Overhaul Ball	6.5 ton (5.9 mt)
1 Sheave Block	17 ton (15.4 mt)

## CAUTION

Overload and anti-two-block systems must be in good operating condition before operating crane. Refer to Owners Manual. Keep at least 3 wraps of loadline on drum at all times. Use only 9/16" diameter cable with 33,600 lb. breaking strength on this machine.

\*First layer speed. For fourth layer speed, multiply \*value by 1.33, for burst speed, multiply by 1.7.

# MOUNTING CONFIGURATIONS

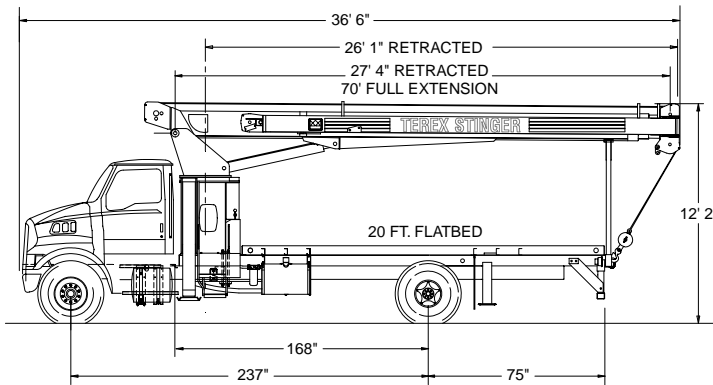

### 3470 Behind Cab (BT) Mounting Configuration

Gross Vehicle Weight Rating .....	33,000 lbs. (14 969 kg)
Front Axle Weight Rating .....	12,000 lbs. (5443 kg)
Rear Axle Weight Rating .....	21,000 lbs. (9526 kg)
Wheelbase .....	237 in. (6020 mm)
Cab to Axle .....	168 in. (4267 mm)
Afterframe .....	75 in. (1905 mm)
Transmission .....	Heavy-Duty (Neutral lock-up required for automatic transmission)
Electrical System .....	Heavy-Duty
Cooling System .....	Heavy-Duty
Frame Section Modulus .....	15.9 in <sup>3</sup> (261 cm <sup>3</sup> )
RBM Per Frame Rail .....	1,400,000 in. lb. (16 130 m. kg)

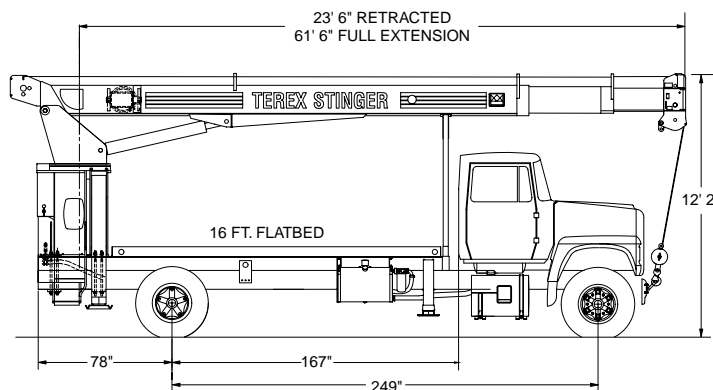

### 3470 Rear Mount (RM) Mounting Configuration\*\*

Gross Vehicle Weight Rating .....	33,000 lbs. (14 969 kg)
Front Axle Weight Rating .....	12,000 lbs. (5443 kg)
Rear Axle Weight Rating .....	21,000 lbs. (9526 kg)
Wheelbase .....	249 in. (6325 mm)
Cab to Axle .....	167 in. (4242 mm)
Afterframe .....	78 in. (1981 mm)
Transmission .....	Heavy-Duty (Neutral lock-up required for automatic transmission)
Electrical System .....	Heavy-Duty
Cooling System .....	Heavy-Duty
Frame Section Modulus .....	20.0 in <sup>3</sup> (328 cm <sup>3</sup> )
RBM Per Frame Rail .....	1,800,000 in. lb. (20 740 m. kg)

\*\*May require counterweight or tandem rear axle. Consult factory.

**Note:** Some standard features for the optional mounting configurations will vary. Consult your Terex Cranes dealer or factory for chassis and mounting requirements.

# TEREX STINGER 3470

## Boom Truck Crane

### SPECIFICATIONS

#### Boom

70 ft. (21.3 m) three section full power mechanically synchronized boom. Patented keel boom design utilizes a keel-shaped baseplate combined with a deep, four plate boom section to optimize strength / rigidity-to-weight ratio. Exclusive, patented color-coded boom and load charts allow the operator to easily and quickly determine boom extension, boom angle and load capacity. Maximum sheave height with three section 70 ft. (21.3 m) boom is 80 ft. (24.4 m). Maximum sheave height with optional two-stage 40 ft. (12.2 m) jib is 120 ft. (36.6 m).

#### Winch

Hydraulic winch with gear motor and planetary reduction gearing provides 2-speed operation. First layer rope pull is 11,400 lbs. (5171 kg). Wire rope size is 9/16" (14 mm) with 33,600 lbs. (15 241 kg) breaking strength.

#### Operating Speeds

Main frame / turret assembly planetary rotation provides 180° rotation (370° with optional front bumper outrigger). Swing rotation is 40 seconds. Boom up/down is 22/22 seconds and boom extend/retract is 50/22 seconds.

#### Hydraulics

Three section pump allows the operator to perform simultaneous crane operations (winch, boom and swing). Capacities are 36, 20 and 11 gpm (136.3, 75.7 and 41.6 lpm). Combined system capacity is 67 gpm (253.6 lpm).

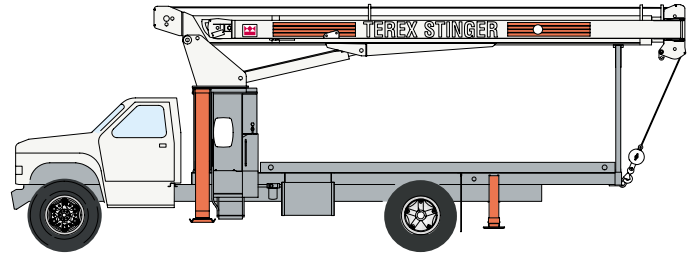

#### Controls

Fully proportional, excellent metering characteristics for precise boom movements. Independent outrigger controls allows the crane to be stable and level in rigorous working conditions. Load Moment Indicating System has audio alarm and functional shut down when operator encounters an overload situation.

#### Outriggers

Wide-stance link-type main outriggers have a 18 ft. 6 in. (5.6 m) pin-to-pin spread when fully extended. A-Frame rear outriggers have 10 ft. 1 in. (3 m) tip-to-tip span.

#### Subframe

Single fabricated, closed-box style subframe yields greater strength and rigidity. Wheel base for standard truck crane mounting configuration is 237 in. (6 m).

### OPTIONS AND ACCESSORIES

Terex Stinger offers a wide range of options and accessories to customize your truck crane to your exact needs.

These include:

- Single and two-stage jibs
- Multi-part load blocks
- Auxiliary winch
- Spin-resistant load line
- Wood, steel or extra heavy duty steel flatbeds
- Radio remote controls
- One-man or two-man baskets
- Self-leveling work platform with radio remote
- Winch drum tensioner
- Continuous rotation
- Oil cooler
- Rear bumper
- Single front bumper outrigger (required for 370° or continuous rotation)
- Hydraulic hose reel
- Hydraulic auxiliary tool circuit

For more information, product demonstration, or details on purchase, lease and rental plans, please contact your local Terex Cranes dealer.

We reserve the right to amend these specifications at any time without notice. The only warranty applicable is our standard written warranty applicable to the particular product and sale. We make no other warranty, expressed or implied.

**INQUIPCO**  
Las Vegas • San Bernardino  
**RENTALS / SALES / PARTS / SERVICE**  
**1-800-598-3465**  
LAS VEGAS 2730 N. HELLIS BLVD. LAS VEGAS, NV 89115  
SAN BERNARDINO 1185 E. COOLEY AVENUE SAN BERNARDINO, CA 92408  
**WWW.INQUIPCO.COM**

## **TEREX CRANES**

550 Old Highway 56  
Olathe, KS 66061-4640 USA  
(913) 782-1200 • FAX: (913) 782-1625  
E-mail: inquire@terexolathe.com

[www.terexlift.com](http://www.terexlift.com)