

# TEREX RT 400 SERIES

rough terrain cranes  
specifications

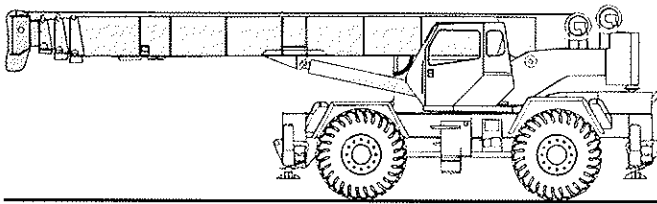

---

## STANDARD BOOM EQUIPMENT

### BOOM

33-105 ft. (10.06-32.00 m), four section full power boom. Telescoping is fully synchronized with single lever control. High-strength, four plate construction with side plate holes providing reduced weight. Anti-friction slide pads. Single boom hoist cylinder.

### BOOM HEAD

Welded to fourth section of boom. Four or five load sheaves and two idler sheaves mounted on heavy duty, anti-friction bearings. Quick reeving boom head eliminates need to remove wedge and socket from rope. Provision made for side-stow jib mounting.

---

## OPTIONAL BOOM EQUIPMENT

### JIBS

33 ft. (10.06 m) side stow swing-on piece lattice type jib. Single sheave mounted on anti-friction bearing. Jib is offsettable at 0°, 15°, or 30°. Maximum tip height is 142 ft. (43.3 m).

33-58 ft. (10.06-17.68 m) side stow swing-on lattice type jib. Single sheave mounted on anti-friction bearing. Jib is extendible to 58 ft. (17.68 m) by means of a 25 ft. (7.62 m) manual pull-out tip section, roller supported for ease of extension. Jib is offsettable at 0°, 15°, or 30°. Maximum tip height is 167 ft. (50.9 m).

### AUXILIARY BOOM HEAD

Removable auxiliary boom head has single sheave mounted on anti-friction bearing. Removable pin-type rope guard for quick reeving. Installs on main boom peak only.

### HOOK BLOCK

Three, four or five sheaves and locking type hook latch. Quick reeving design does not require removal of wedge and socket from rope.

### HOOK & BALL

7.0 ton (6.3 mt) top swivel ball with hook and hook latch.

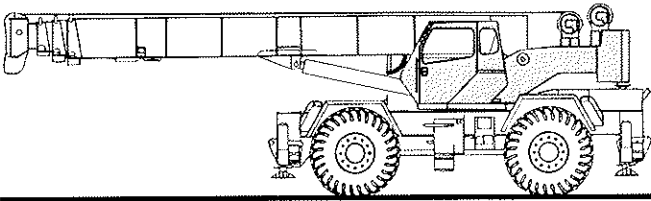

## STANDARD UPPERSTRUCTURE EQUIPMENT

### UPPERSTRUCTURE FRAME

All welded one-piece structure fabricated with high tensile strength alloy steel. Counterweight is bolted to frame.

### TURNTABLE CONNECTION

Swing bearing is single row, ball-type, with internal teeth. The swing gear is bolted to revolving upperstructure and to carrier frame.

### SWING

A hydraulic motor drives a double planetary reduction gear for precise and smooth swing function. Swing speed (no load) is 2.5 rpm.

### SWING BRAKE

Heavy duty multiple disc swing brake is mechanically actuated from operator's cab by foot pedal. Brake may be locked on or used as a momentary brake. A separate 2-position mechanical house lock is also provided.

### RATED CAPACITY INDICATOR

Rated Capacity Indicator with visual and audible warning system and automatic function disconnects. Pictographic display includes: boom radius, boom angle, boom length, allowable load, actual load, and percentage of allowable load registered by bar graph. Operator settable alarms provided for swing angle, boom length, boom angle, tip height, and work area exclusion zone. Anti-two block system includes audio/visual warning and automatic function disconnects.

### OPERATOR'S CAB

Environmental cab with all steel construction, optimized visibility, tinted safety glass throughout, and rubber floor matting is mounted on vibration absorbing pads. The cab has a sliding door on the left side, framed sliding window on the right side, hinged tinted glass skylight and removable front windshield to provide

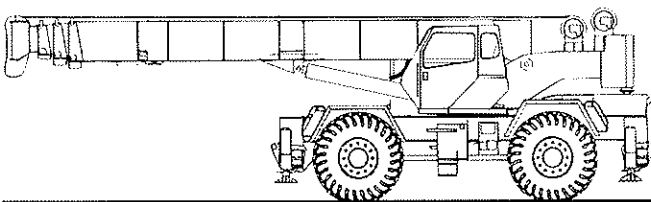

## STANDARD CARRIER EQUIPMENT

### CARRIER CHASSIS

Chassis is designed and built with four-wheel drive and four-wheel steer (4x4x4). Has box beam type construction with reinforcing cross members, a precision machined turntable mounting plate and integrally welded outrigger boxes. Decking has anti-skid surfaces, including tool storage compartment and access ladders left and right side and front and rear corners.

### AXLES AND SUSPENSION

Rear axle is a planetary drive/steer type with automatic oscillation lockouts that engage when the superstructure is swung 10° in either direction. Front axle is a planetary drive/steer type, rigid mounted to the frame for increased stability.

optimized visibility of the load open or closed. Acoustical foam padding insulates against sound and weather. The deluxe six-way adjustable operator's seat is equipped with a torsion bar suspension and includes head and arm rests.

### CONTROLS

All control levers and pedals are positioned for efficient operation. Hand-operated control levers include swing, boom telescope, boom hoist, single lever two-speed main winch, shift, vernier adjustable hand throttle and two position house lock. Switches include ignition, engine stop, steering mode, parking brake, and outrigger controls. Foot control pedals include swing brake, boom raise, boom lower, service brake and accelerator.

### INSTRUMENTATION AND ACCESSORIES

In-cab gauges include air pressure, bubble level, engine oil pressure, fuel, engine temperature, voltmeter, transmission temperature, and transmission oil pressure. Indicators include low air, high water temperature/low oil pressure/high transmission temperature audio/visual warning, low coolant audio/visual warning, hoist drum rotation indicator and Rated Capacity Indicator. Accessories include fire extinguisher; light package including headlights, tail lights, brake lights, directional signals, four-way hazard flashers, and back-up lights with audio pulsating back-up alarm; windshield and skylight washers/wipers; R.H. and L.H. rear view mirrors; dome light; dash lights; and seat belt.

### HYDRAULIC CONTROL VALVES

Valves are mounted on the upperstructure and are easily accessible. Valves include one four-spool main valve for boom hoist, telescope, main winch, and main winch boost; one single-spool valve for swing. A single spool valve is included for future installation of auxiliary winch. High pressure regeneration feature provides 2-speed boom extension. Quick disconnects are provided for quick attachment of pressure check gauges.

### OPTIONAL EQUIPMENT

Auxiliary Winch • 360° House Lock • Heater/Defroster • Air Conditioner • Tachometer • Work Lights • Revolving Amber Light • Independent Rear Wheel Steering • Roof Mounted Spotlight

### STEERING

Hydraulic four-wheel power steering for two-wheel, four-wheel, or crab steer is easily controlled by steering wheel.

Turning radius to center of outside tire.

	21.00 x 25	26.5 x 25
Two-wheel	38' 0.6" (11.6 m)	38' 4.2" (11.7 m)
Four-wheel	20' 10.4" (6.4 m)	21' 1.9" (6.5 m)

### TRANSMISSION

Full power-shift transmission with integral torque converter has neutral safety system, 6 speeds forward, and 3 speeds reverse. Automatic pulsating backup alarm.

## STANDARD CARRIER EQUIPMENT (continued)

### MULTI-POSITION OUT & DOWN OUTRIGGERS

Fully independent hydraulic outriggers may be utilized fully extended to 22 ft. (6.71 m), in their 1/2 extended position, or fully retracted. Easily removable floats, each with an area of 254 in<sup>2</sup> (1639 cm<sup>2</sup>), stow on the carrier frame. Complete controls and sight leveling bubble are located in the operator's cab.

### WHEELS & TIRES

Disc type wheels with full tapered bead seat rim. 150.50 in (3.82 m) wheelbase.

### TIRES

26.50x25, 26 P.R. (standard)  
21.00x25, 28 P.R. (optional)

## HYDRAULIC SYSTEM

### HYDRAULIC PUMPS

Three gear type pumps, one single and two in tandem, driven off the transmission. Combined system capability is 119 gpm (450 lpm). Includes pump disconnect.

#### Main and Auxiliary Winch Pump

59.5 gpm (225.2 lpm) @ 3,500 psi (246.1 kg/cm<sup>2</sup>)

#### Boom Hoist, Telescope Pump

38.5 gpm (145.7 lpm) @ 3,500 psi (246.1 kg/cm<sup>2</sup>)

#### Power Steering, Outrigger and Swing Pump

21 gpm (79.5 lpm) @ 2,500 psi (175 kg/cm<sup>2</sup>)

### SERVICE BRAKES

Air brakes on all four wheels; 20 1/4" x 4" (51.43x1010 cm) drum brakes.

### PARKING BRAKE

Front and rear axles equipped with spring-set, air-released emergency/parking chambers.

### OPTIONAL EQUIPMENT

Cold Weather Starting Aid • Immersion Heater • Rear Axle Centering Light • Pintle Hook • Clearance Lights • 24" (0.61 m) Aluminum Outrigger Floats • 31.5" (0.80 m) Stroke Jack Cylinders • Front Mounted Winch-20,000 lbs (9072 kg)

### FILTRATION

Full flow oil filtration system with bypass protection includes a removable 60 mesh (250 micron) suction screen-type filter and 5 micron replaceable return line filter.

### HYDRAULIC RESERVOIR

All steel, welded construction with internal baffles and diffuser. Provides easy access to filters and is equipped with an external sight level gauge. The hydraulic tank is pressurized to aid in keeping out contaminants and in reducing potential pump cavitation. Capacity is 114 gal (432 liters). Swing-away hydraulic oil cooler is standard.

## MAIN WINCH SPECIFICATIONS

Hydraulic winch with planetary reduction gearing provides 2-speed operation with equal speeds for power up and down. Winch is equipped with an integral automatic brake, tapered drum flanges, electronic drum rotation indicator, and drum roller.

### PERFORMANCE

Max. line speed (no load)

	LO-RANGE	HI-RANGE
First layer	177 fpm (54 m/min)	293 fpm (89 m/min)
Fifth layer	257 fpm (78 m/min)	425 fpm (130 m/min)

Max. line pull-first layer

15,000 lbs (6804 kg)

Permissible line pull

10,000 lbs (4536 kg)

### DRUM DIMENSIONS

10.62 in (270 mm) drum diameter  
20.9 in (531 mm) length  
19.8 in (503 mm) flange dia.  
Cable: 5/8 in. x 500 ft (15.9 mm x 152.4 m)  
Cable type: 6 x 19 IWRC-XIPS  
regular lay preformed

### DRUM CAPACITY

Max. Storage: 899 ft (274 m)  
7th layer not a working layer  
Max. Useable: 738 ft (225 m)\*

\* Based on min. flange height above top layer to comply with ANSI B30.5

### OPTIONAL AUX. WINCH

Hydraulic winch, power up and down, equal speed, planetary reduction with integral automatic brake, tapered drum flanges, electronic drum rotation indicator, and drum roller.

### STANDARD: Performance

Max. line speed (no load)

Fifth layer 338 fpm (103 m/min)

Max. line pull

First layer 10,100 lbs (4582 kg)

### Drum Dimensions

10.5 in (267 mm) drum diameter  
16.1 in (408 mm) length  
17.8 in (452 mm) flange diameter  
Cable: 1/2 in x 500 ft (12.7 mm x 152.4 m)  
Cable type: 6 x 19 IWRC-XIPS regular lay preformed.

### Drum Capacity

Max. storage: 815 ft (248 m).

### HI-TORQUE:

Same as low speed main winch.

**OPTIONAL AUXILIARY WINCH** - 9/16 in. (15.88 mm) rotation resistant compacted strand, 18 x 19 or 19 x 19. Minimum break strength 18.5 tons (16.6 mt).

### OPTIONAL HOIST LINE

**MAIN WINCH** - 5/8" (14.29 mm) rotation resistant, compacted strand, 16 x 19 or 19 x 19. Minimum break strength 22.7 tons (20.4 mt).

## ENGINE SPECIFICATIONS

Make and Model	Cummins 6BTA5.9	Caterpillar 3116 DITA
Type	6 cylinder	6 cylinder
Bore and Stroke	4.02 x 4.72 in (102x120 mm)	4.12 x 5.0 in (105x127 mm)
Displacement	359 cu in (5.9 l)	402 cu in (6.6 l)
Gross HP	174 hp (130 kw) @ 2500 rpm	175 hp (130 kw) @ 2400 rpm
Gross Torque	455 lb•ft (617 N•m) @ 1500 rpm	490 lb•ft (664 N•m) @ 1450 rpm
Aspiration	turbocharged & aftercooled	turbocharged & aftercooled
Air Filter	dry type	dry type
Electrical System	12 volt	12 volt
Alternator	102 amp	115 amp
Battery	(2) 12V-1600 CCA	(2) 12V-1600 CCA
Fuel Capacity	50 gal (189 l)	50 gal (189 l)

## PERFORMANCE (Cummins 6BTA5.9 Engine)

Transmission Gear	Forward Drive	Maximum Speed	Maximum Tractive Effort	Gradeability @ Stall
1	4-wheel	2.4 mph 3.9 km/h	60,538 lbs 27,460 kg	127.6%
2	4-wheel	4.2 mph 6.8 km/h	34,255 lbs 15,538 kg	48.5%
3	4-wheel	5.6 mph 9.0 km/h	26,061 lbs 11,821 kg	34.7%
4	2-wheel	9.8 mph 15.8 km/h	14,765 lbs 6697 kg	18.0%
5	2-wheel	13.9 mph 22.4 km/h	10,410 lbs 4722 kg	12.0%
6	2-wheel	24.1 mph 38.8 km/h	5,960 lbs 2703 kg	5.9%

All performance data is based on a gross vehicle weight of 75,000 lbs (34,014 kg), 26.5x25 tires, 4x4 drive. Performance may vary due to engine performance. Gradeability data is theoretical and is limited by tire slip, stability, or engine oil pan design.

# GENERAL DIMENSIONS

**NOTES:**

- Dimensions given assume the boom is fully retracted in travel position and 26.50x25 tires.
- Minimum ground clearance under:
  - transmission - 25.25" (0.64m)
  - axle bowls - 22.25" (0.57m)
  - tie rods - 25.5" (0.65m)

\*\* The winch cable roller and drum rotation indicator increase the overall height by 4.50"

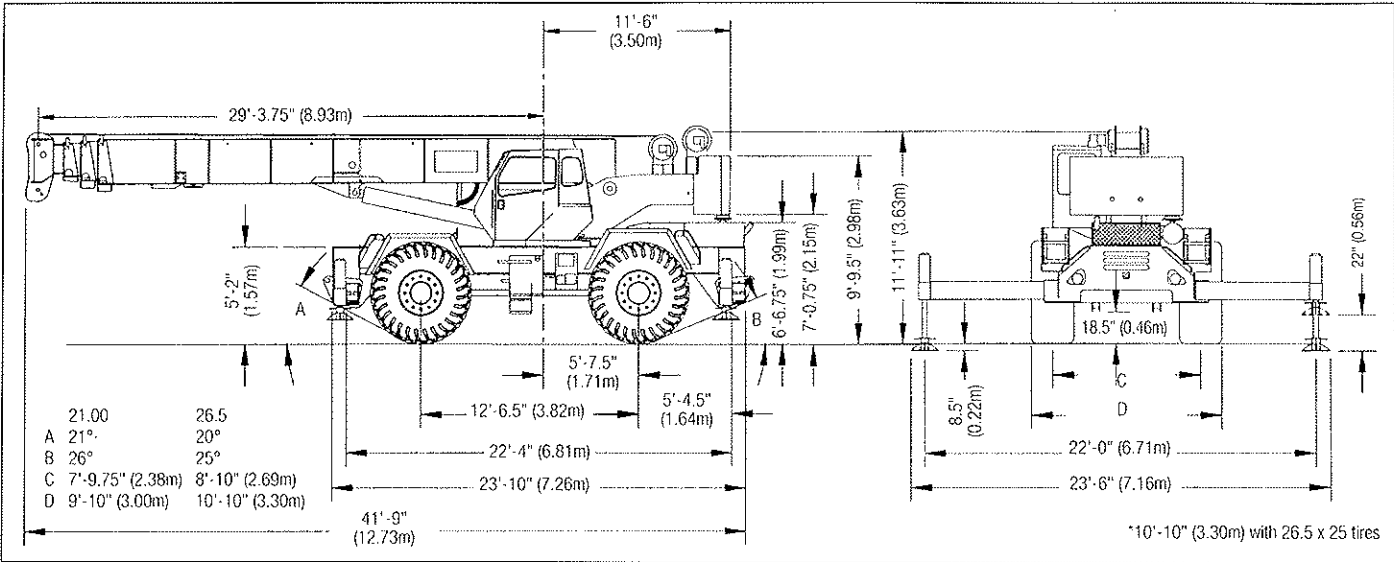

WEIGHTS & AXLE LOADS	GROSS WEIGHT LBS.	UPPER FACING FRONT		GROSS WEIGHT KG.	UPPER FACING FRONT	
		FRONT	REAR		FRONT	REAR
Basic Crane with 14,000 lb. (6349 kg) Counterweight and 26.5 x 25 26 PR Tires	76,095	37,192	38,903	34 516	16 870	17 646
<b>Add Options:</b>						
33' (10.06 m) Swing-on jib (Stowed)	+ 1,705	+2,850	-1,145	+ 773	+ 1293	- 520
33'-58' (10.06-17.68 m) Swing-On Jib (Stowed)	+ 2,545	+4,000	-1,455	+ 1154	+ 1814	- 660
Auxiliary Boom Head	+ 100	+ 285	- 185	+ 45	+ 129	- 84
Caterpillar 3116 DITA Engine	+ 180	- 15	+ 195	+ 82	- 7	+ 195
Aux. Winch, 1/2"x450' Wire Rope, Drum Roller	- 65	+ 15	- 80	- 29	+ 7	- 22
Hi-Torq Aux Winch 5/8"x500' Rope, Drum Roller	+ 298	- 45	+ 343	+ 135	- 20	+ 155
50T (45.3 mt) 6-Sheave Hook Block	+ 913	+1,367	- 454	+ 414	+ 620	- 206
50T (45.3 mt) 5-Sheave Hook Block	+ 888	+1,329	- 441	+ 403	+ 603	- 200
7.0T (6.3 mt) Hook and Ball (In tool box)	+ 240	+ 290	- 50	+ 109	+ 130	- 21
<b>Pintle Hook:</b>						
Front	+ 45	+ 60	- 15	+ 20	+ 27	- 7
Rear	+ 45	- 25	+ 70	+ 20	- 11	+ 31
<b>Substitute:</b>						
360° Mechanical House Lock	+ 85	- 38	+ 47	+ 39	- 17	+ 22
21.00 x 25 28 PR Tires	- 460	- 230	- 230	- 208	- 104	- 104
5/8" x 500' of 18x19 class spin resistant wire rope	+ 35	- 5	+ 40	+ 16	- 2	+ 18

NOTE: Weights are for factory supplied equipment and are subject to 2% variation due to manufacturing tolerances.

WE RESERVE THE RIGHT TO AMEND THESE SPECIFICATIONS AT ANY TIME WITHOUT NOTICE. THE ONLY WARRANTY APPLICABLE IS OUR STANDARD WRITTEN WARRANTY APPLICABLE TO THE PARTICULAR PRODUCT AND SALE. WE MAKE NO OTHER WARRANTY, EXPRESSED OR IMPLIED.

**INQUIPCO**  
Las Vegas • San Bernardino

**RENTALS / SALES / PARTS / SERVICE**

LAS VEGAS 2730 N. HELLIS BLVD. LAS VEGAS, NV 89115	<b>1-800-598-3465</b>	SAN BERNARDINO 1185 E. COOLEY AVENUE SAN BERNARDINO, CA 92408
--	-----------------------	---

**WWW.INQUIPCO.COM**

**TEREX CRANES**  
Waverly, Iowa

106 12th Street S.E. • Waverly, IA 50677-9466 USA  
(319) 352-3920 • FAX: (319) 352-5727