

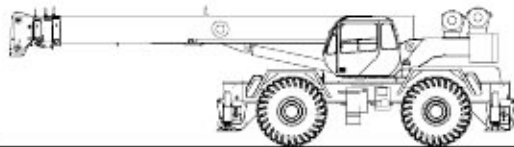

RT600 SERIES

rough terrain crane
specification



STANDARD BOOM EQUIPMENT BOOM

35-111 ft. (10.67-33.53 m), four section full power boom. Telescoping is mechanically synchronized with single lever control. The synchronization system consists of a single telescope cylinder and high strength leaf chains to extend and retract the third section and the tip section. The boom is a high-strength four plate design, welded inside and out with anti-friction slide pads. Boom side plates are made with stamped impressions to reduce weight and increase strength. A single boom hoist cylinder provides for boom elevation of -4 to 76 degrees. Maximum tip height 115 ft (35.05 m).

BOOM HEAD

Welded to fourth section of boom. Five or six nylon load sheaves and two idler sheaves mounted on heavy duty, anti-friction bearings. Quick reeving boom head. Provisions made for side-stow jib mounting.

OPTIONAL BOOM EQUIPMENT JIBS

32 ft. (9.68 m) side stow swing-on one-piece lattice type jib. Single nylon sheave mounted on anti-friction bearing. Jib is offsettable at 0°, 15°, or 30°. Maximum tip height is 146 ft. (44.50m).

33-57 ft. (10.15-17.30 m) side stow swing-on lattice type jib. Single nylon sheave mounted on anti-friction bearing. Jib is extendible to 57 ft. (17.30 m) by means of a 25 ft. (7.62 m) manual pull-out tip section, roller supported for ease of extension. Jib is offsettable at 0°, 15°, or 30°. Maximum tip height is 170 ft. (51.82 m).

AUXILIARY BOOM HEAD

Removable auxiliary boom head has single nylon sheave mounted on anti-friction bearing. Removable pin-type rope guard for quick reeving. Installs on main boom peak only. Removal is not required for jib use.

HOOK BLOCK

Five metallic sheaves on anti-friction bearings with hook and hook latch. Quick reeving design does not require removal of wedge and socket from rope.

HOOK & BALL

12 ton (10.9 mt) top swivel ball with hook and hook latch.

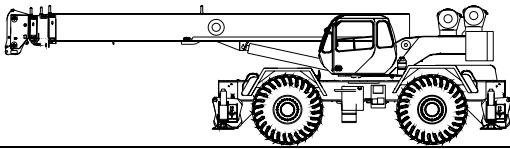

STANDARD UPPERSTRUCTURE EQUIPMENT

UPPERSTRUCTURE FRAME

All welded one-piece structure fabricated with high tensile strength alloy steel. Counterweight is bolted to frame.

TURNTABLE CONNECTION

Swing bearing is a single row, ball type, with internal teeth. The swing bearing is bolted to the revolving upperstructure and to the carrier frame.

SWING

A hydraulic motor drives a double planetary reduction gear for precise and smooth swing function. Swing speed (no load) is 1.9 rpm.

SWING BRAKE

Heavy duty multiple disc swing brake is mechanically actuated from operator's cab by foot pedal. Brake may be locked on or used as a momentary brake. A 360° house mechanical house lock is standard.

RATED CAPACITY INDICATOR

Rated Capacity Indicator with visual and audible warning system and automatic function disconnects. Second generation pictographic display includes: boom radius, boom angle, boom length, allowable load, actual load, and percentage of allowable load registered by bar graph. Operator settable alarms provided for swing angle, boom length, boom angle, tip height, and work area exclusion zone. Anti-two block system includes audio/visual warning and automatic function disconnects.

OPERATOR'S CAB

Environmental cab with all steel construction, optimum visibility, tinted safety glass throughout, and rubber floor matting is mounted on vibration absorbing pads. The cab has a sliding door on the left side, framed sliding window on the right side, hinged tinted all glass skylight and removable front windshield to provide optimum visibility of the load open or closed. A coustical foam padding insulates against sound and weather. The deluxe six-way adjustable seat is equipped with a mechanical suspension and includes head and arm rests.

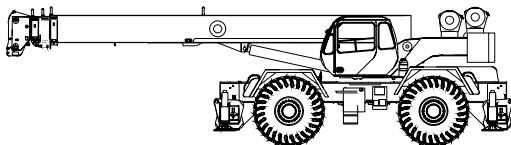

CONTROLS

Armrest mounted dual axis controls for winch(s), swing, and boom elevation. Winch rotation indication incorporated into control handles. Armrest swings up to improve access and egress. Vernier adjustable hand throttle included. Steering column mounted turn signal, wiper, and shift controls. Switches include ignition, engine stop, lights, horn, roof window wiper, defroster, steering mode, parking brake, outriggers, 360° house lock, etc. Horn and winch speed shift switches are mounted in the levers. Foot control pedals include swing brake, boom telescope, service brake, and accelerator.

INSTRUMENTATION AND ACCESSORIES

In-cab gauges include air pressure, bubble level, engine oil pressure, fuel, engine temperature, voltmeter, transmission temperature, and transmission oil pressure. Indicators include low air, high water temperature, low oil pressure, high transmission temperature, and low coolant level audio/visual warning, hoist drum rotation indicator(s), and Rated Capacity Indicator. Accessories include fire extinguisher; light package including headlights, tail light, brake lights, directional signals, four-way hazard flashers, dome light, and back-up lights with audible back-up alarm; windshield washer/wiper; skylight wiper; R.H. and L.H. rear view mirrors; dash lights; and seat belt. Circuit breakers protect electrical circuits.

HYDRAULIC CONTROL VALVES

Valves are mounted on the rear of the upperstructure and are easily accessible. Valves have electric/hydraulic operators and include one pressure compensated two spool valve for boom elevation and telescope. One pressure compensated two spool valve for main and auxiliary winch, and one single spool valve for swing. Quick disconnects are provided for ease of installation of pressure check gauges.

OPTIONAL EQUIPMENT

Auxiliary Winch C Single axis armrest mounted controllers CLP Heater/Defroster CHydraulically powered Air Conditioner with or without hydraulic heater CDiesel Heater/Defroster CWork Lights CRotating Beacon

STANDARD CARRIER EQUIPMENT

CARRIER CHASSIS

Chassis is Terex designed with four-wheel drive and four-wheel steer (4X4X4). Has box-type construction with reinforcing cross members, a precision machined turn table mounting plate and integrally welded outrigger boxes. Decking has anti-skid surfaces, including between the frame rails lockable front tool storage compartment, and access steps and handles on the left and right sides and on all four corners.

AXLES AND SUSPENSION

Rear axle is a planetary drive/steer type with 10.5 in (0.26m) of total oscillation. Automatic oscillation lockouts that engage when the superstructure is swung 10° in either direction. Front axle is a planetary drive/steer type, rigid mounted to the frame for increased stability.

STEERING

Hydraulic four-wheel full power steering for two-wheel, four-wheel coordinated, or four-wheel crab steer is easily controlled by steering wheel. A rear axle centering light is provided.

	Turning radius (to C of outside tire)	Curb clearance Radius
Two-wheel:	41' 7" (12.7 m)	43' 2" (13.2 m)
Four-wheel:	22' 10" (7.0 m)	24' 7" (7.5 m)

TRANSMISSION

Range shift type power-shift power-shift transmission with integral torque converter provides 6 speeds forward and 6 speeds reverse with neutral safety start. Four wheel drive engages automatically with low range and two wheel drive with high range. A utomatic pulsating back-up alarm.

STANDARD CARRIER EQUIPMENT (continued)

MULTI-POSITION OUT & DOWN OUTRIGGERS

Fully independent hydraulic outriggers may be utilized fully extended to 24 ft. (7.32 m) centerline to centerline, in their 1/2 extended position, or fully retracted for maximum flexibility. Easily removable Almag floats, each with an area of 254 in² (1639 cm²), stow on the outrigger boxes at their point of use. Complete controls and a sight leveling bubble are located in the operator's cab.

WHEELS & TIRES

Disc type wheels with full tapered bead seat rim. 157.56 in (4.0 m) wheelbase.

TIRES

Wide earthmover (E3) style tread tires provide life and flotation. 29.50x25, 28 P.R. - std.

SERVICE BRAKES

Split system air over hydraulic 18.5" (470 mm) diameter disc dual caliper brakes on all wheels.

PARKING BRAKE

Front axle equipped with spring-set, air released parking brake

OPTIONAL EQUIPMENT

Immersion Heater CPintle Hook CClearance Lights CIndependent Rear Wheel Steer CFour Mode Rear Wheel Steer C20,000 lb line pull front mounted winch

HYDRAULIC SYSTEM

HYDRAULIC PUMPS

Three gear type pumps, one single and two in tandem, driven off the transmission. Combined system capability is 113 gpm (428 lpm). Includes pump disconnect on winch pump.

Main and Auxiliary Winch Pump

52.7 gpm (199.5 lpm) @ 4,500 psi (316.4 kg/cm²)

Boom Hoist, Telescope Pump

37.3 gpm (141.2 lpm) @ 3,500 psi (246.1 kg/cm²)

Power Steering, Outrigger and Swing Pump

18.7 gpm (70.8 lpm) @ 3,500 psi (246.1 kg/cm²)

FILTRATION

Full flow oil filtration system with bypass protection includes a removable 60 mesh (250 micron) suction screen-type filter and 5 micron replaceable return line filter.

HYDRAULIC RESERVOIR

All steel, welded construction with internal baffles and diffuser. Provides easy access to filters and is equipped with an external sight level gauge. The hydraulic tank is pressurized to aid in keeping out contaminants and in reducing potential pump cavitation. Capacity is 116 gal (439 liters). Hydraulic oil cooler is standard.

MAIN WINCH SPECIFICATION

Hydraulic winch with bent axis piston motor and planetary reduction gearing provides 2-speed operation with equal speeds for power up and down. Winch is equipped with an integral automatic brake, grooved drum, tapered flanges, standard cable roller on drum, and an electronic drum rotation indicator.

PERFORMANCE	LO-RANGE	HI-RANGE
Max. line speed (no load)		
First layer	187 fpm (57.0m/min)	300 fpm (91.4 m/min)
Fifth layer	269 fpm (82.0 m/min)	431 fpm (131.4 m/min)
Max. line pull-first layer	18,450 lbs (8 369 kg)	10,002 lbs (4 537 kg)
Max. line pull-fifth layer	12,845 lbs (5 826 kg)	6,963 lbs (3 158 kg)
Permissible line pull	13,800 lbs (6 260 kg)	

OPTIONAL AUX. WINCH

Hydraulic 2-speed winch with bent axis piston motor, equal speed power up and down, planetary reduction with integral automatic brake, grooved drum with tapered flanges, drum roller, and rotation indicator.

PERFORMANCE	
Max. line speed (no load)	
Fifth layer	431 fpm (131.4 m/min)
Max. line pull	
First layer	18,450 lbs (8 369 kg)

DRUM DIMENSIONS AND CAPACITY (Same as main winch)

DRUM DIMENSIONS	DRUM CAPACITY
13.00 in (330 mm) drum diameter	Max. Storage: 561 ft (171.0 m)
20.16 in (512 mm) length	Max. Useable: 561 ft (171.0 m)*
21.5 in (546 mm) flange dia.	*Based on minimum flange height above top layer to comply with ANSI B 30.5
Cable: 3/4" x 600 ft (19 mm x 182.9 m)	
Cable type 3/4" (19mm) 6x19 IWRC, XIPS, right regular lay, preformed.	
Min breaking strength 29.4 tons (26.6 mt)	

OPTIONAL HOIST LINE

MAIN WINCH AND OPTIONAL AUXILIARY WINCH - 3/4" (19mm) rotation resistant compacted strand 34x7 Grade 1960. Min breaking strength 34.5 tons (31.7 mt).

ENGINE SPECIFICATIONS

Make and Model	Cummins QSB-215
Type	6 cylinder
Bore and Stroke	4.02 x 4.72 in (102x120 mm)
Displacement	359 cu in (5.9 l)
Rated HP	215 hp (160 kw) @ 2500 rpm
Maximum Gross HP	225 hp (168 kw) @ 2300 rpm
Maximum Gross Torque	655 lbCft(888 Ncm) @ 1500 rpm
Aspiration	turbocharged & charge air cooled
Air Filter	dry type
Electrical System	12 volt
Alternator	102 amp
Battery	(2) 12V-1900 CCA
Fuel Capacity	50 gal (189 l)

PERFORMANCE (Standard Engine)

Trans- mission Gear	Forward Drive	Maximum Speed	Maximum Tractive Effort	Grade- ability @ Stall
1	4-wheel	1.9 mph (3.1 kph)	86,330 lbs (39 159 kg)	127.6%
2	4-wheel	3.8 mph (6.1 kph)	41,547 lbs (18 845 kg)	48.5%
3	4-wheel	9.6 mph (15.4 kph)	15,220 lbs (6 904 kg)	34.7%
4	2-wheel	5.2 mph (8.4 kph)	29,686 lbs (13 465 kg)	18.0%
5	2-wheel	10.3 mph (16.6 kph)	14,260 lbs (6 468 kg)	12.0%
6	2-wheel	23.4 mph (37.7 kph)	5,211 lbs (2 364 kg)	5.9%

All performance data is based on a gross vehicle weight of 92,000 lbs (41 730 kg), 29.5x25 tires, 4x4 drive. Performance may vary due to engine performance. Gradeability data is theoretical and is limited by tire slip, machine stability, or oil pan design.

GENERAL DIMENSIONS

NOTES:

- Dimensions given assume the boom is fully retracted in travel position and 29.50x25 tires.
- Minimum ground clearance under:
 - transmission - 29.00"
 - axle bowls - 23.62"
 - tie rods - 23.88"

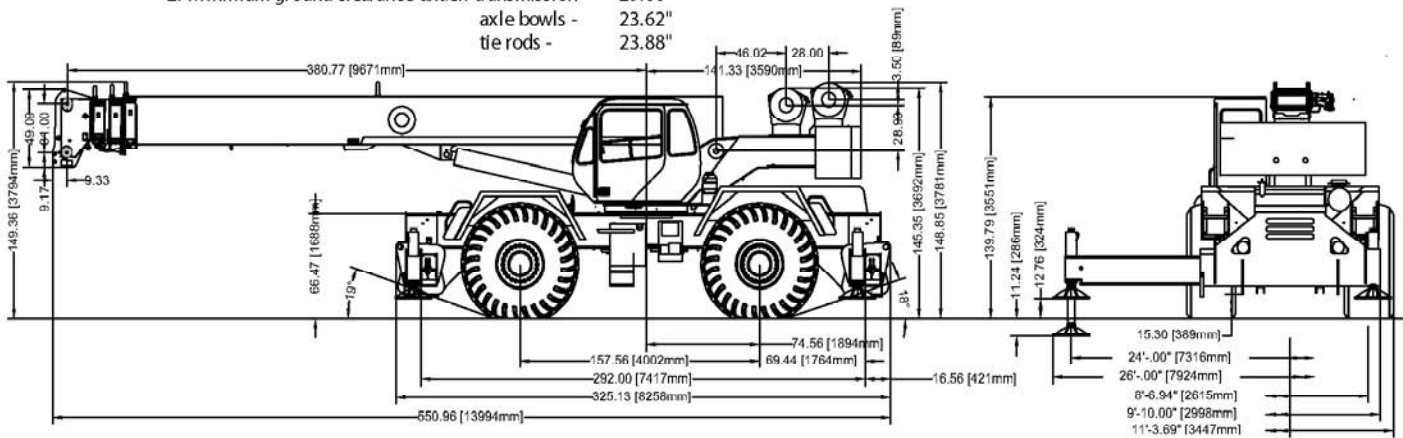

WEIGHTS & AXLE LOADS	GROSS WEIGHT LBS.	UPPER FACING FRONT		GROSS WEIGHT KG.	UPPER FACING FRONT	
		FRONT	REAR		FRONT	REAR
Basic Crane with 14,200 lb. (6440 kg) Counterweight	85,694	45,238	40,456	38 870	20 520	18 350
Add Options:						
32' (9.68 m) Swing-on Jib (Stowed)	+ 1,270	+ 2,205	- 935	+ 576	+ 1 000	- 424
33'-57' (10.15-17.30 m) Swing-on Jib (Stowed)	+ 2,170	+ 3,580	- 1,410	+ 984	+ 1 624	- 640
Auxiliary Boom Head	+ 125	+ 365	- 240	+ 57	+ 166	- 109
Auxiliary Winch with Wire Rope, Condrds, Etc.	+ 584	- 30	+ 614	+ 265	- 14	+ 279
75T (68.0 mt) 5-Sheave Hook Block	+1,040	+ 1,971	- 931	+ 472	+ 894	- 422
60T (54.4 mt) 5-Sheave Hook Block	+ 1204	+ 2,233	-1,029	+ 546	+ 1013	- 467
20T (18.1 mt) 1-Sheave Hook Block	+ 570	+ 936	- 366	+ 259	+ 425	- 166
12T (19.9 mt) Hook and Ball (In tool box)	+ 419	+ 443	- 24	+ 190	+ 201	- 11
Pintle Hook:						
Front	+ 45	+ 60	- 15	+ 20	+ 27	- 7
Rear	+ 45	- 25	+ 70	+ 20	- 11	+ 31
Substitute: 600' of 34x7 class spin resistant wire rope	+ 98	- 17	+ 115	+ 44	- 8	+ 52

NOTE: Weights are for Terex supplied equipment and are subject to 2% variation due to manufacturing tolerances.

WE RESERVE THE RIGHT TO AMEND THESE SPECIFICATIONS AT ANY TIME WITHOUT NOTICE. THE ONLY WARRANTY APPLICABLE IS OUR STANDARD WRITTEN WARRANTY APPLICABLE TO THE PARTICULAR PRODUCT AND SALE. WE MAKE NO OTHER WARRANTY, EXPRESSED OR IMPLIED.



TEREX

TEREX Cranes
106 12th Street S.E.
Waverly, IA 50677-9466 USA
TEL: +1 (319) 352-3920
FAX: +1 (319) 352-5727
EMAIL: inquire@terexwaverly.com
WEB: terex.com



Las Vegas • San Bernardino
RENTALS / SALES / PARTS / SERVICE

1-800-598-3465
LAS VEGAS 2730 N. NELLIS BLVD. LAS VEGAS, NV 89115
SAN BERNARDINO 1185 E. COOLEY AVENUE SAN BERNARDINO, CA 92408

WWW.INQUIPCO.COM